

**PRIVATE VEHICLE SHIPPING DOCUMENT FOR MOTORCYCLE**

<b>TCMD DATA</b> 	1. DOC ID (1-3) TP1	2. CONTAINER NO. (4-8)	3. CONSIGNOR (9-14)	4. COMM-EX (15-19)	5. POE (21-23)	6. POD (24-26)	7. PACK (28-29)
8. TRANSPORTATION CONTROL NUMBER (30-46)			9. CONSIGNEE (47-52)	10. RDD (54-56)	11. TR ACCOUNT (64-67)	12. PIECES (68-71)	13. WEIGHT (72-76)
14. CUBE (77-78)	15. DOC ID (1-3) TP8	16. POV YR, MAKE (9-14)		17. OWNER'S LAST NAME (54-66)		18. F & MI (67-68)	19. GRADE (69-70)
20. STATE (71-72)	21. LICENSE NUMBER (73-77)	21. COLOR (78-80)		22. BODY TYPE	23. VEHICLE IDENTIFICATION NUMBER		
24. ODOMETER READING		25. VESSEL (Voyage Number)		26. AUTHORIZATION CHARGES PAID, ETC.		27. DATE LOADED (YYYYMMDD)	

28. STOWAGE LOCATION	29. BILLING ADDRESS FOR NOTIFICATION PURPOSES
----------------------	---

<b>30. Inspected in my presence, condition acknowledged as marked below, and conditions governing shipment on back accepted.</b>  a. DATE (YYYYMMDD)  b. SIGNATURE OF OWNER OR AGENT  c. NAME OF AGENT (Last, First, Middle Initial) (Print)  d. STREET ADDRESS  e. CITY, STATE, AND ZIP CODE	f. (1) USER CODE	(2) INSPECTION	(3) DATE (YYYYMMDD)	(4) INSPECTOR'S PRINTED NAME (Last, First, Middle Initial)
	<b>X</b>	(a) Turn in joint inspection - owner/agent & Government representative		
	<b>T</b>	(b) POE use (Optional)		
	<input type="checkbox"/>	(c) POE check in stow/condition when stuffed in container		
	<input type="checkbox"/>	(d) POD check in stow/condition when removed from container		
	<input type="checkbox"/>	(e) Release of custody by discharge stevedore		
	<b>*</b>	(f) POD use (Optional)		

Retain this form for proof of shipment for return transport at government expense or proof of POV Import Control Program participation.

**31. AFTER INITIAL INSPECTION, RECORD ONLY MARS EXPOSING BARE METAL AND/OR STRUCTURAL DAMAGE.**

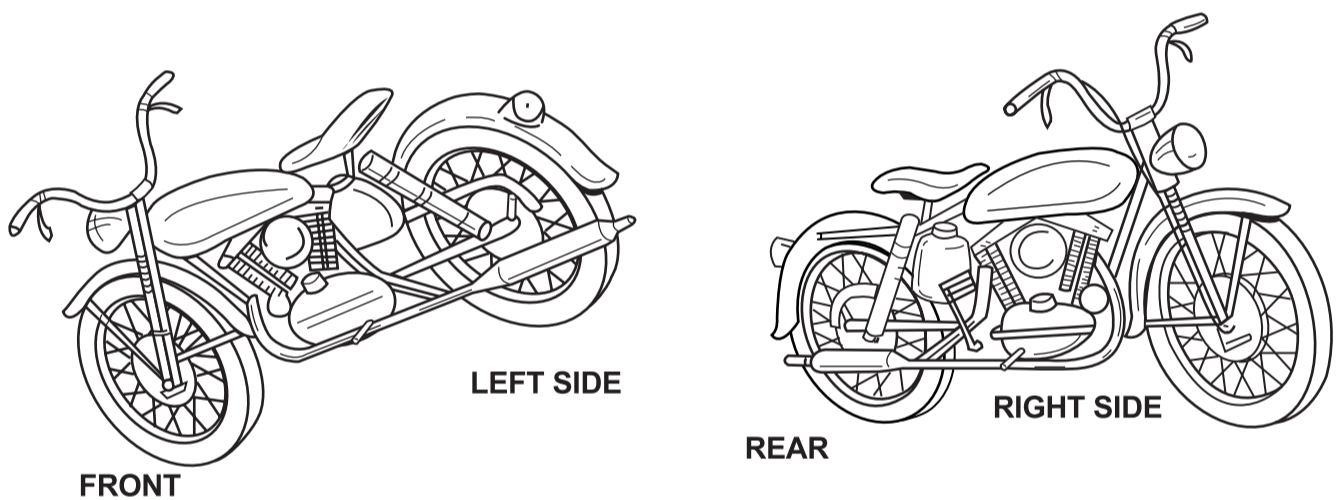

**32. ENTRY NUMBER (US Customs use only)**

<b>POV CONDITION CODES</b>	BE - Bent BR - Broken CH - Chipped	CR - Cracked DE - Dent GO - Gouged	LO - Loose MA - Marred MG - Missing	MI - Mildewed PF - Paint Faded RS - Rusted	RU - Rubbed SC - Scratched SO - Soiled	TO - Torn WO - Badly Worn
----------------------------	--	--	---	--	--	------------------------------

33. INTERIOR CONDITION	CODE	34. ACCESSORIES	IN BOX	LOOSE	35. PROCESSING SERVICE	POE	POD
a. FRONT SEATS		a. CATALYTIC CONVERTER/PELLETS			a. ADD/DRAIN FUEL		
b. REAR SEAT		b. SIDE MIRRORS			b. CONNECT/DISCONNECT BATTERY		
c. REAR MIRROR		c. ANTENNA			c. PACK ACCESSORIES		
d. FRONT SEAT BELTS		d. FAN BELT			d. OTHER		
e. REAR SEAT BELTS		e. FENDER SKIRTS					
f. ASH TRAYS		f. FIRE EXTINGUISHER					
g. FLOOR MATS		g. FIRST AID KITS					
h. DOOR PANELS		h. CIGARETTE LIGHTER					
i. ARM RESTS		i. HAND TOOLS/FLASHLIGHT					
j. REAR SPEAKERS (Additional)		j. HUB CAPS					
k. CUSHION		k. JACK/LUG WRENCH					
l. UPHOLSTERY		l. JUMPER CABLES					
m. RADIO (AM, FM, Tape)		m. LUGGAGE RACK					
n. CB RADIO		n. BLANKET					
o. CARPET		o. WARNING TRIANGLE/TROUBLE LIGHT					
p. CLOCK		p. SPARE TIRE					

**36. DOD POV IMPORT CONTROL PROGRAM (X appropriate box)**

THE MOTORCYCLE DESCRIBED ABOVE:

<input type="checkbox"/>	a. Was manufactured after January 1, 1978 and does not have a manufacturers label affixed certifying its conformance with US EPA emissions standards. The owner must post a bond with US Customs prior to vehicle release at the US Port of Entry.
<input type="checkbox"/>	b. Was manufactured after January 1, 1978 and does have a manufacturers label affixed certifying its conformance with US EPA emissions standards.
<input type="checkbox"/>	c. Is not subject to the regulations under the Clean Air Act because it was manufactured before January 1, 1978.

**CONDITIONS GOVERNING SHIPMENT**

**I UNDERSTAND AND ACCEPT THE TERMS UNDER WHICH THIS VEHICLE WILL BE TRANSPORTED OVERSEAS AS SET FORTH IN EXISTING REGULATION, i.e.:**

- 1. That only one (1) privately-owned vehicle is being transported overseas under permanent change of station orders for the owner and/or his family as personal property, and that it is free of any legal encumbrance that would preclude its shipment and is not intended for resale. Owner must also retain a second (extra) set of keys.
  
- 2. That this vehicle contains no personal property in excess of that authorized in regulations of the Service concerned. I further understand that personal property shipped will only include those items that can fit in the container normally provided for vehicular tools and accessories.
  
- (3) That no land transportation is authorized at Government expense except as specified in Section 12 of the Missing Persons Act, as amended, and 10 USC Section 2634(a).

(4) That failure of the owner to provide sufficient permanent type antifreeze to protect the cooling system to minus 20 degrees F (or lower if determined to be necessary by the shipping port) relieves the Government of any liability for damage due to freezing.

THIS CERTIFICATE constitutes authority for the placing in available storage chosen by the port, at the complete expense of the owner and at no cost whatsoever to the Government, the vehicle herein property of above named owner, (1) by the port of embarkation in the event that shipment of privately-owned vehicles therefrom is suspended or terminated because of a national emergency, and (2) by the port of debarkation in the event that the vehicle is not picked up by the owner or his agent within forty-five (45) days after dispatch of the notification of its arrival.

I further understand that should the vehicle be placed in such storage, the Government, thenceforth, would not be responsible for its release or return to the owner or agent.

**37. DELIVERY RECEIPT**

**a. EXCEPTIONS**

(1) BY OWNER

(2) VERIFICATION OR DISAGREEMENT WITH REASONS

**b. TERMINAL SERVICE - PICKUP** *(X as applicable. If unsatisfactory, specify.)*

**SATISFACTORY**

**UNSATISFACTORY**

**38. MISCELLANEOUS INFORMATION**

**39. I HEREBY ACKNOWLEDGE RECEIPT OF MY VEHICLE IN THE CONDITION IN WHICH I TURNED IT IN TO THE U.S. GOVERNMENT REPRESENTATIVE FOR TRANSSHIPMENT, EXCEPT AS NOTED ABOVE.**

**a. SIGNATURE OF OWNER OR AGENT**

**b. DATE (YYYYMMDD)**

**40. SIGNATURE OF VERIFYING U.S. GOVERNMENT REPRESENTATIVE**

**41. NAME OF PORT**