

UNCLASSIFIED

Manpower and Personnel Directorate (J-1)

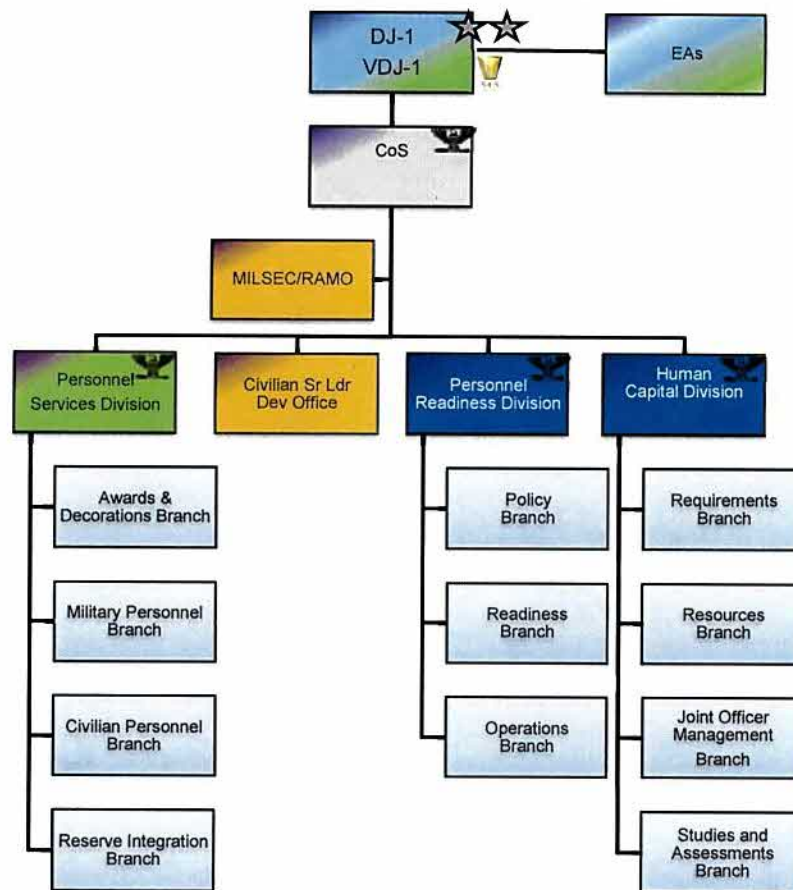

UNCLASSIFIED

J-1 Personnel Readiness Division

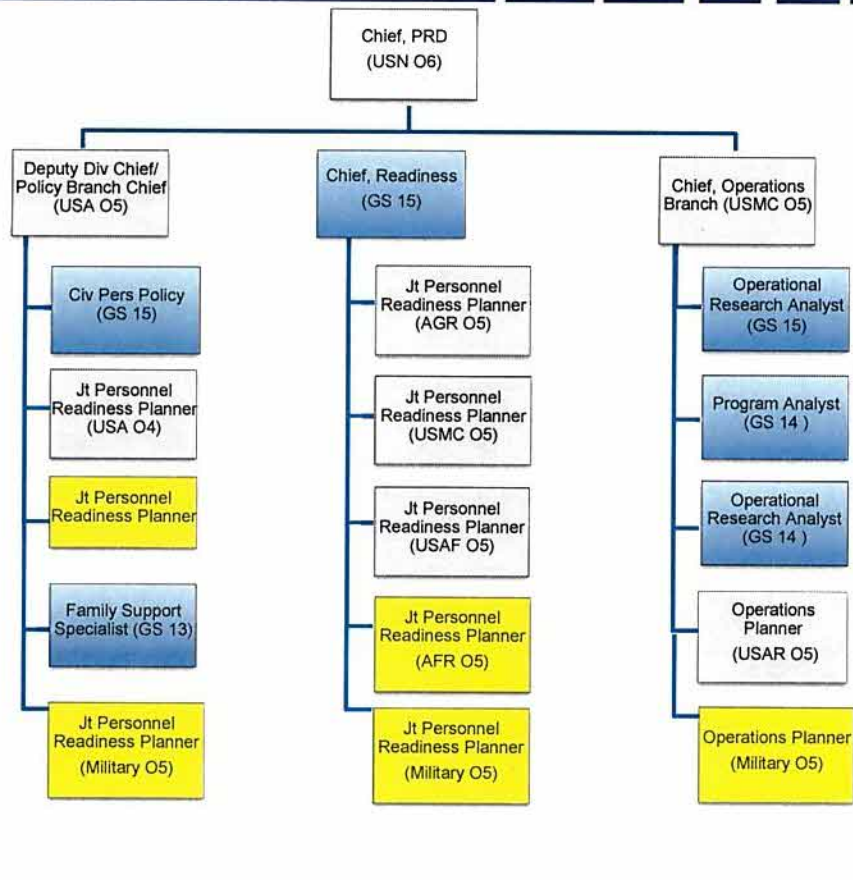



J-1 Human Capital Division

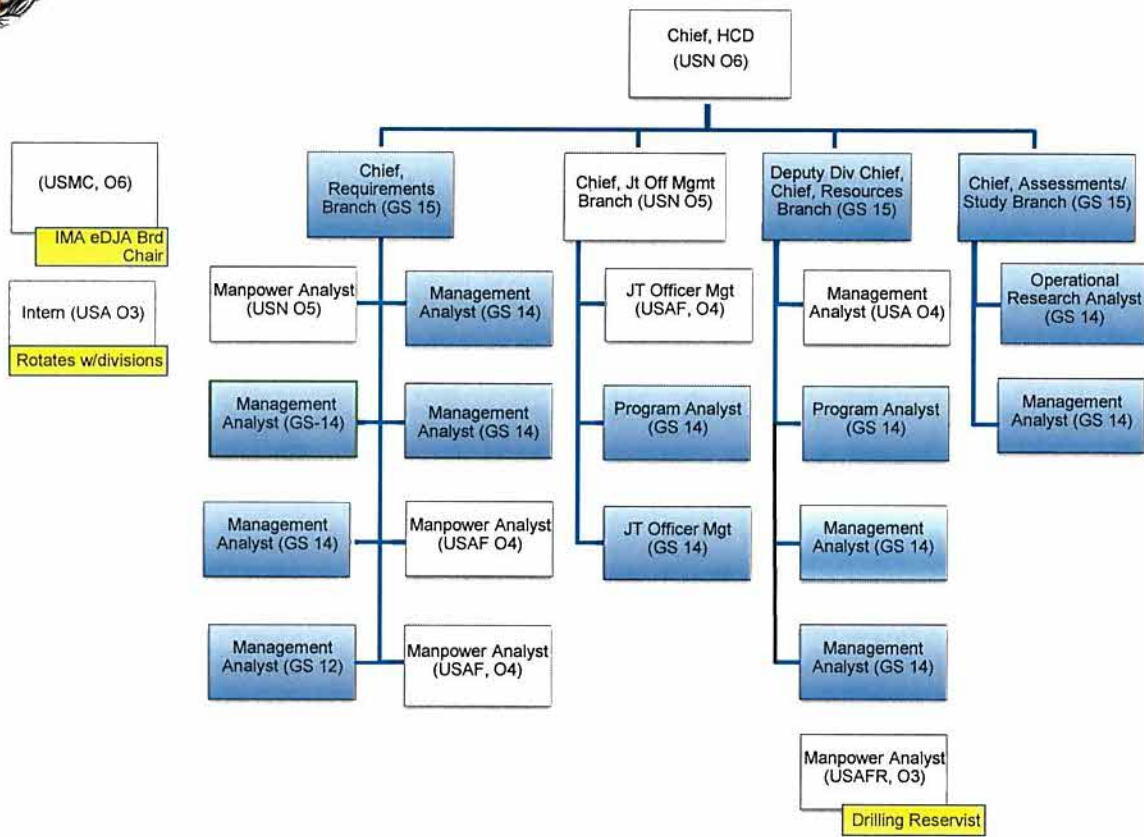



J-1 Personnel Services Division

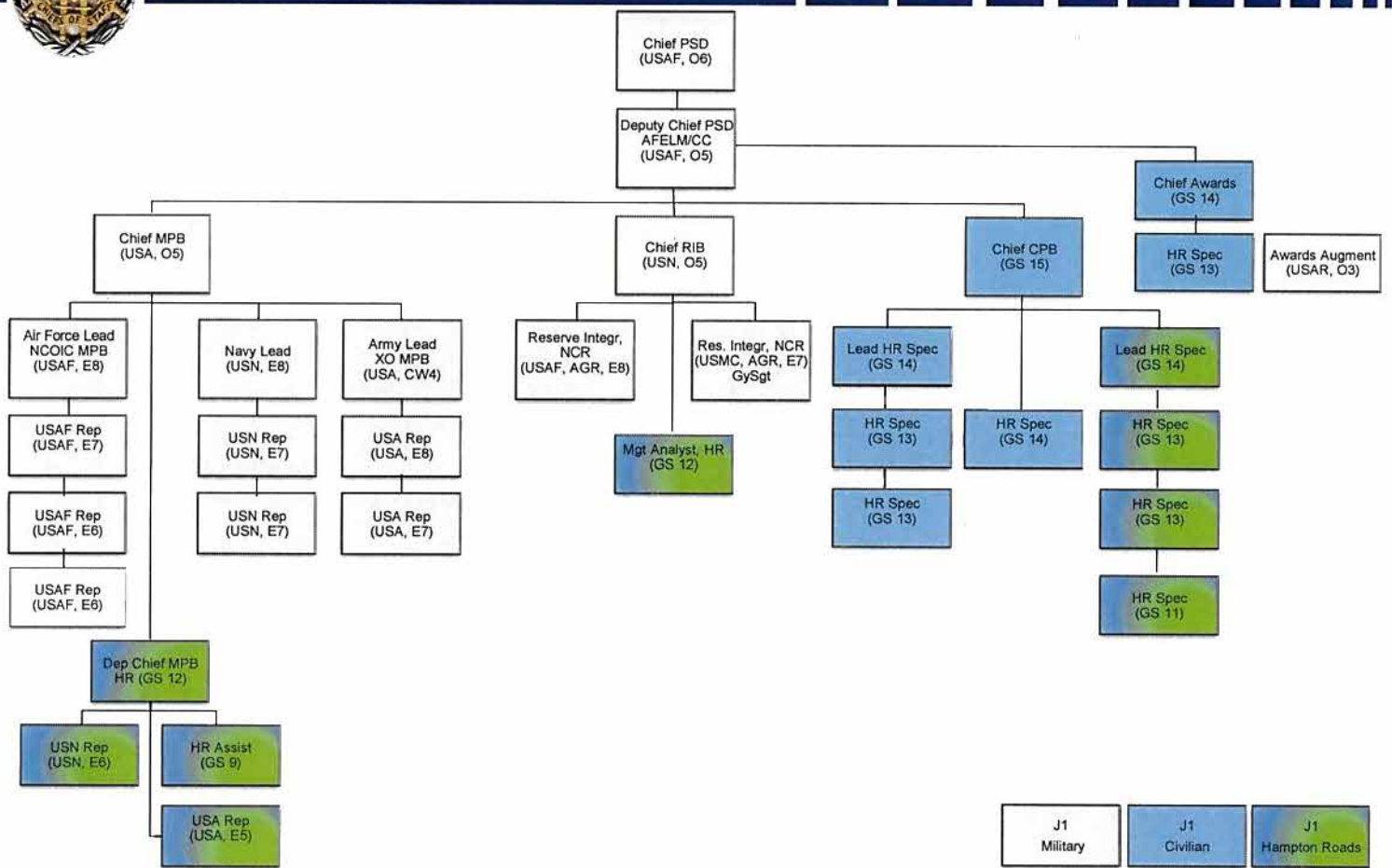

UNCLASSIFIED

MILSEC/RAMO

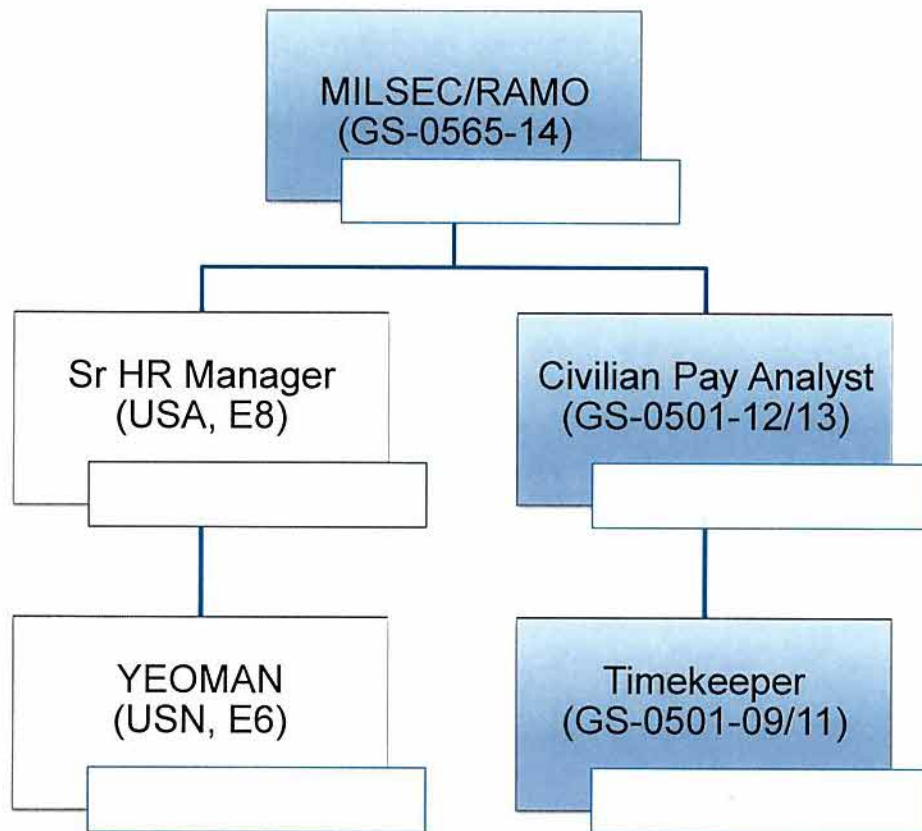

UNCLASSIFIED



J2 Proposed Organizational Structure

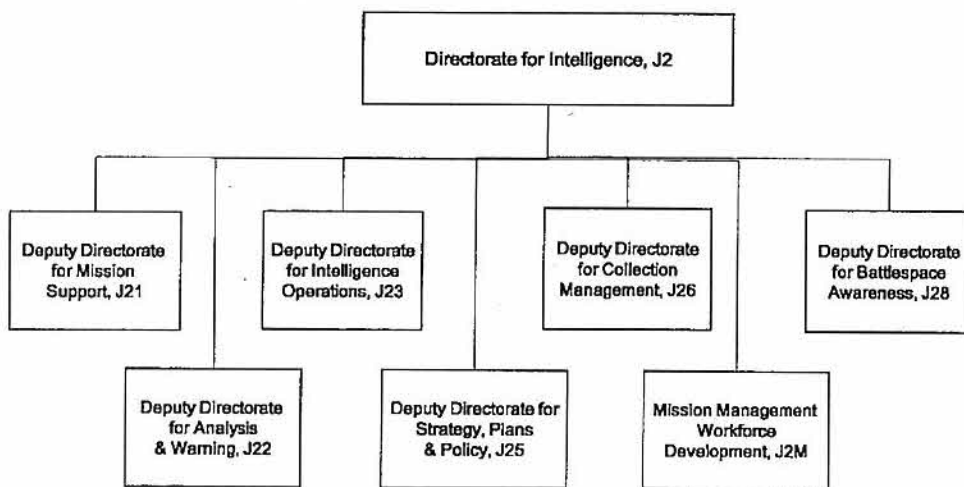

J-3 OPERATIONS DIRECTORATE

9 May 2019

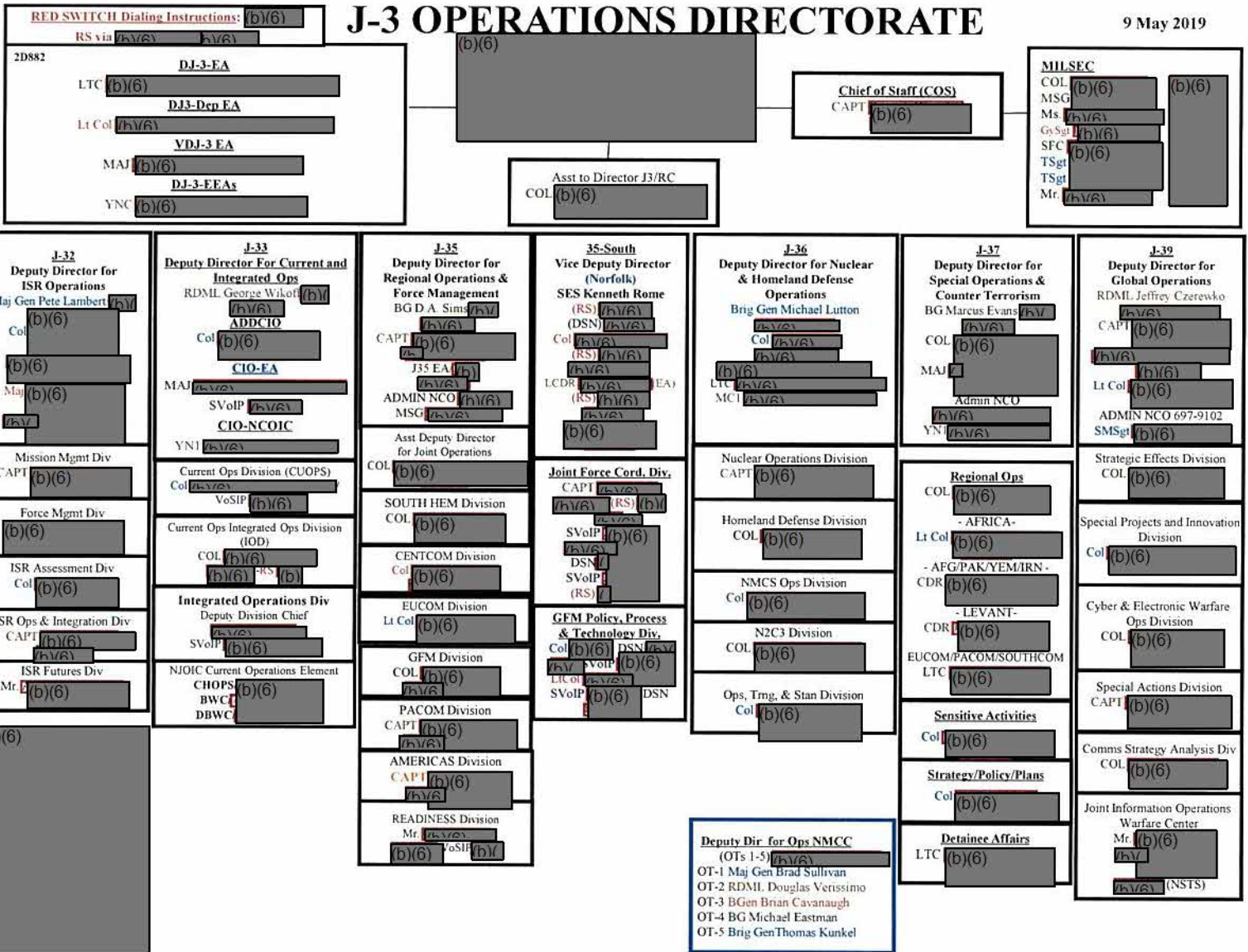



The Directorate for Logistics

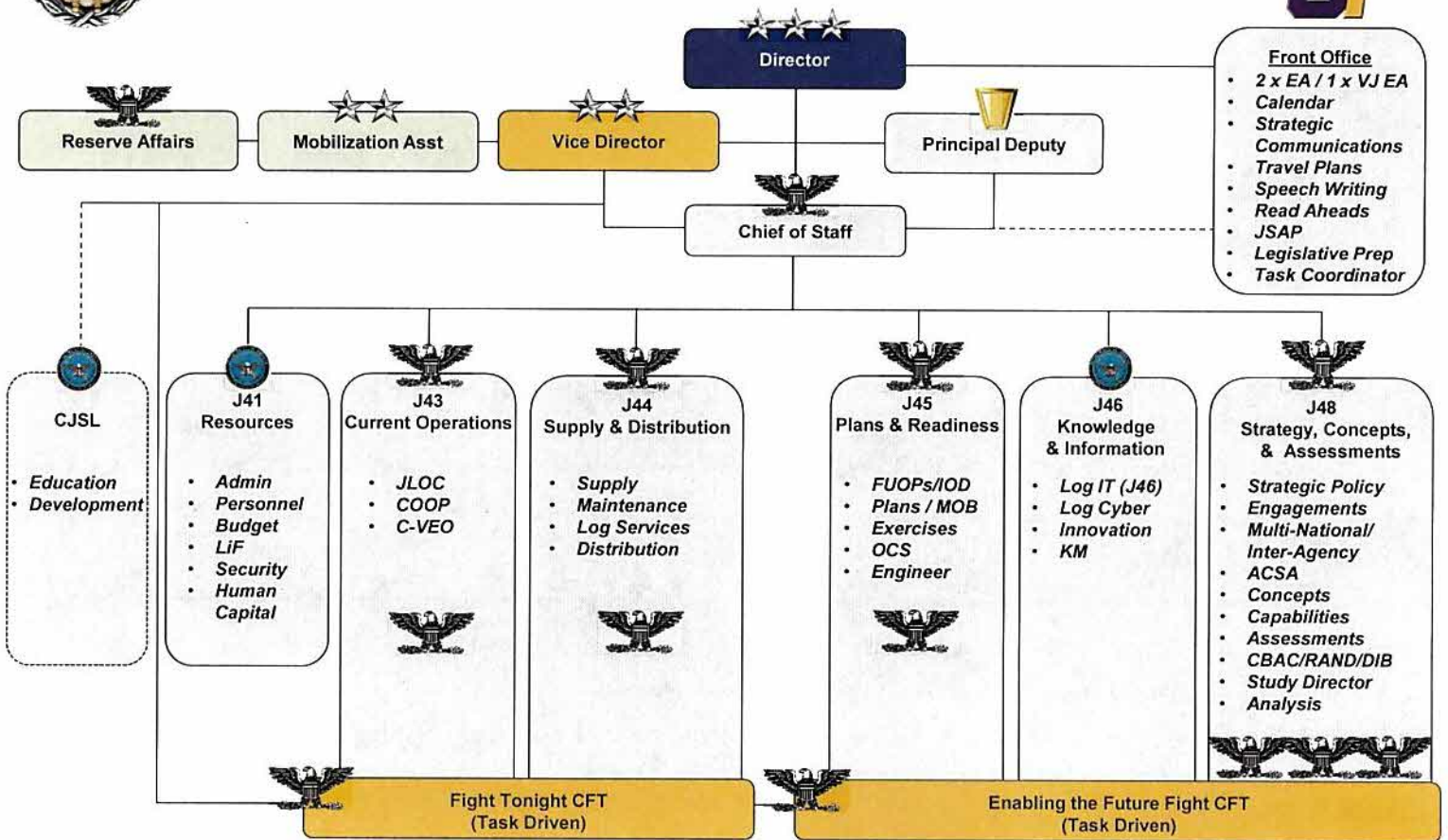

UNCLASSIFIED

J4 Front Office

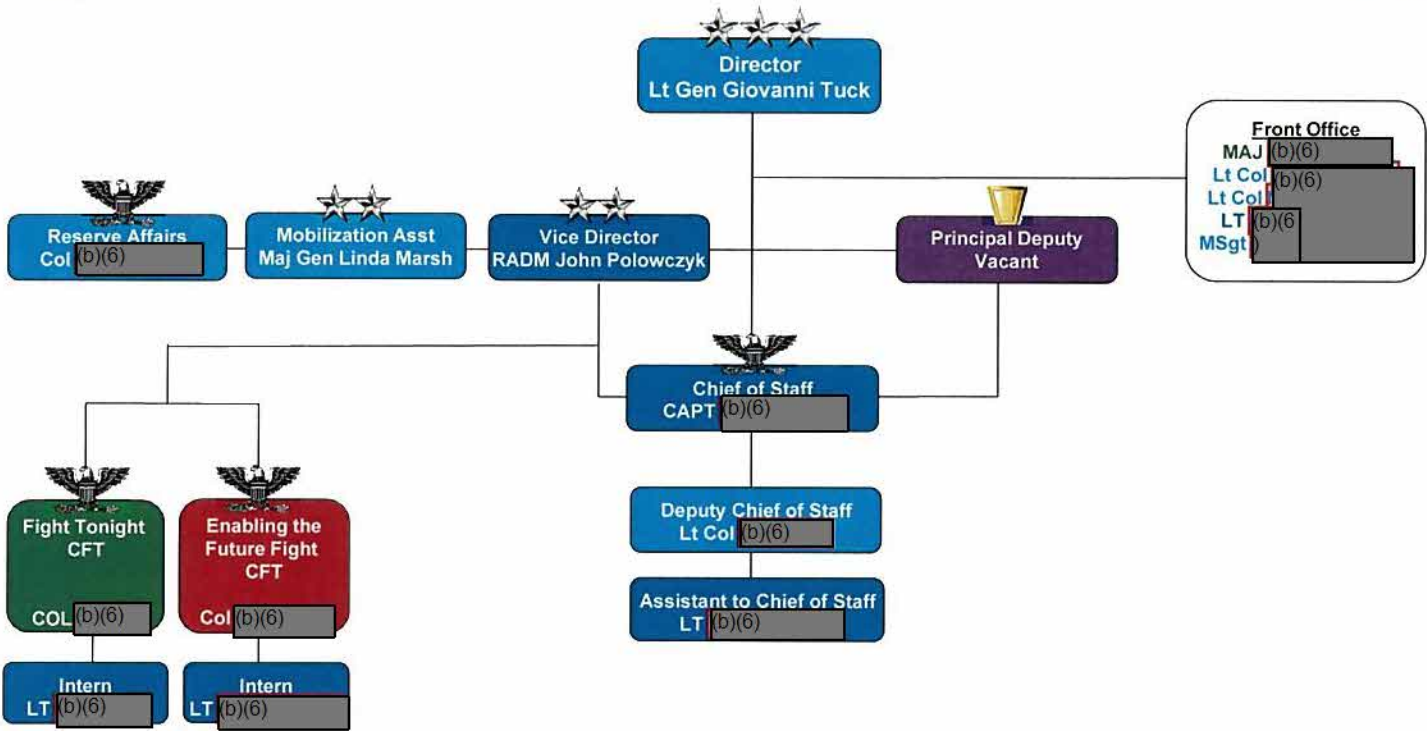

Legend				
USN	USA	USAF	USMC	DoD Civilian

UNCLASSIFIED

J41 Resources Division

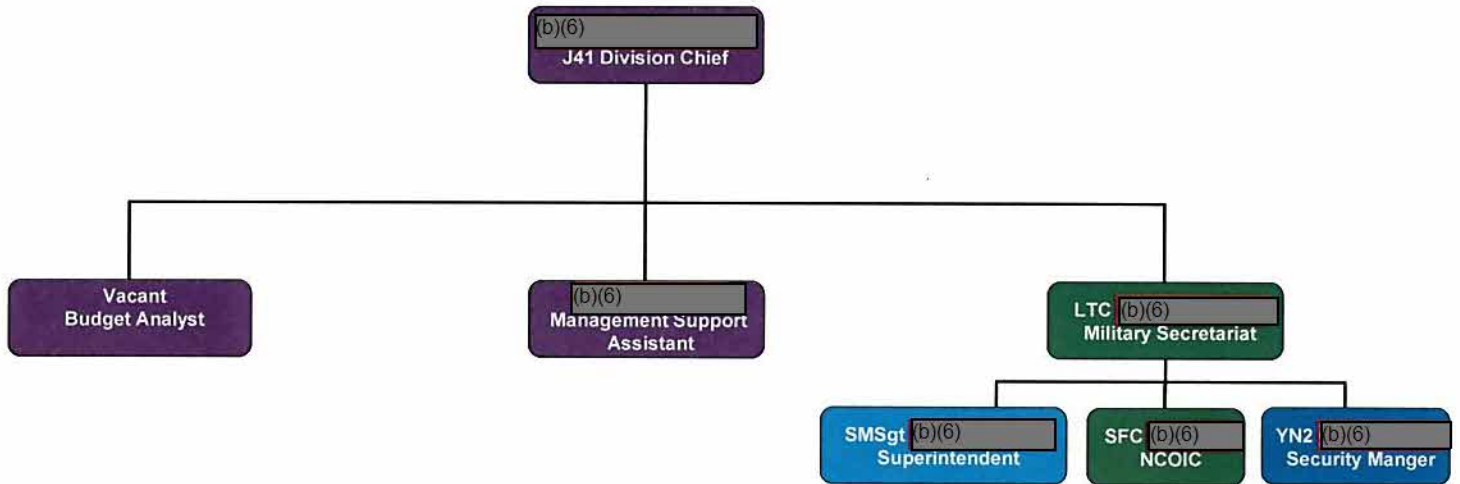

Legend									
	USN		USA		USAF		USMC		DoD Civilian



J43

Current Operations Division

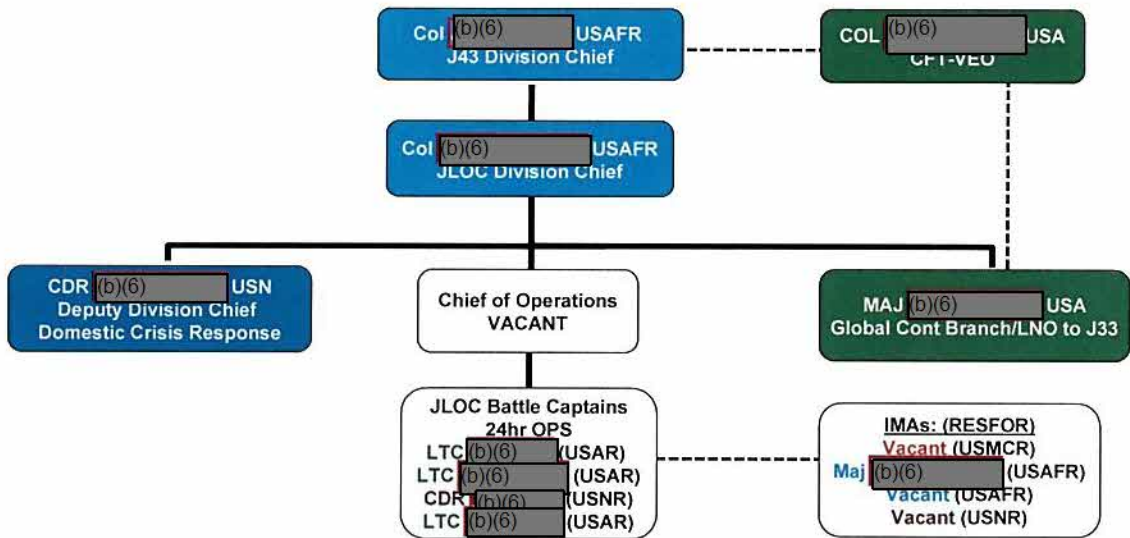

Legend				
USN	USA	USAF	USMC	DoD Civilian

UNCLASSIFIED



J44 Supply & Distribution Division

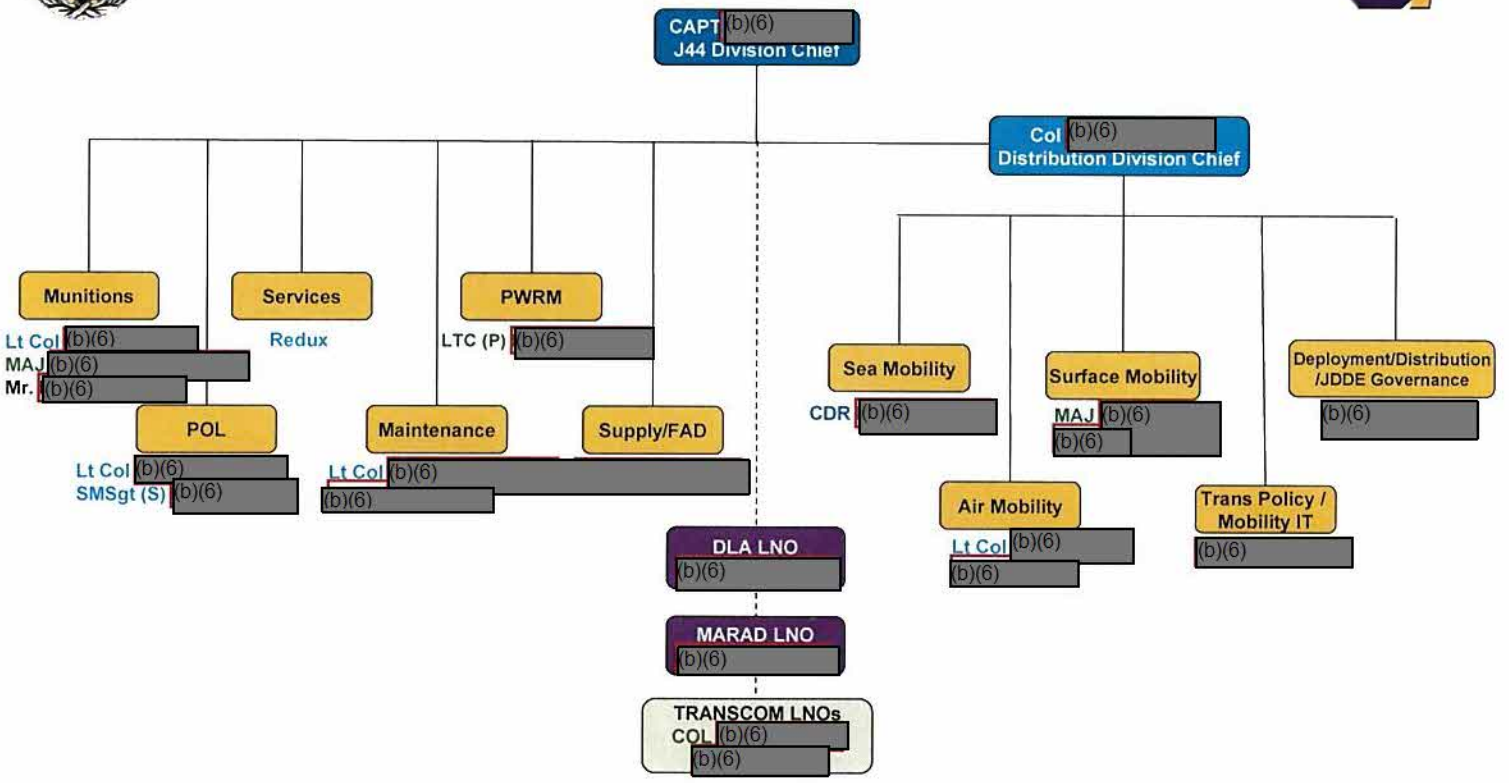

Legend					
 	 	 	 	 	
USN	USA	USAF	USMC	DoD Civilian	

J45

Plans & Readiness Division

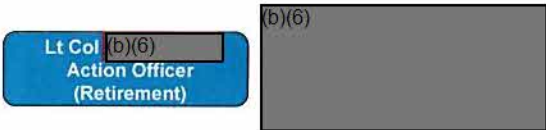
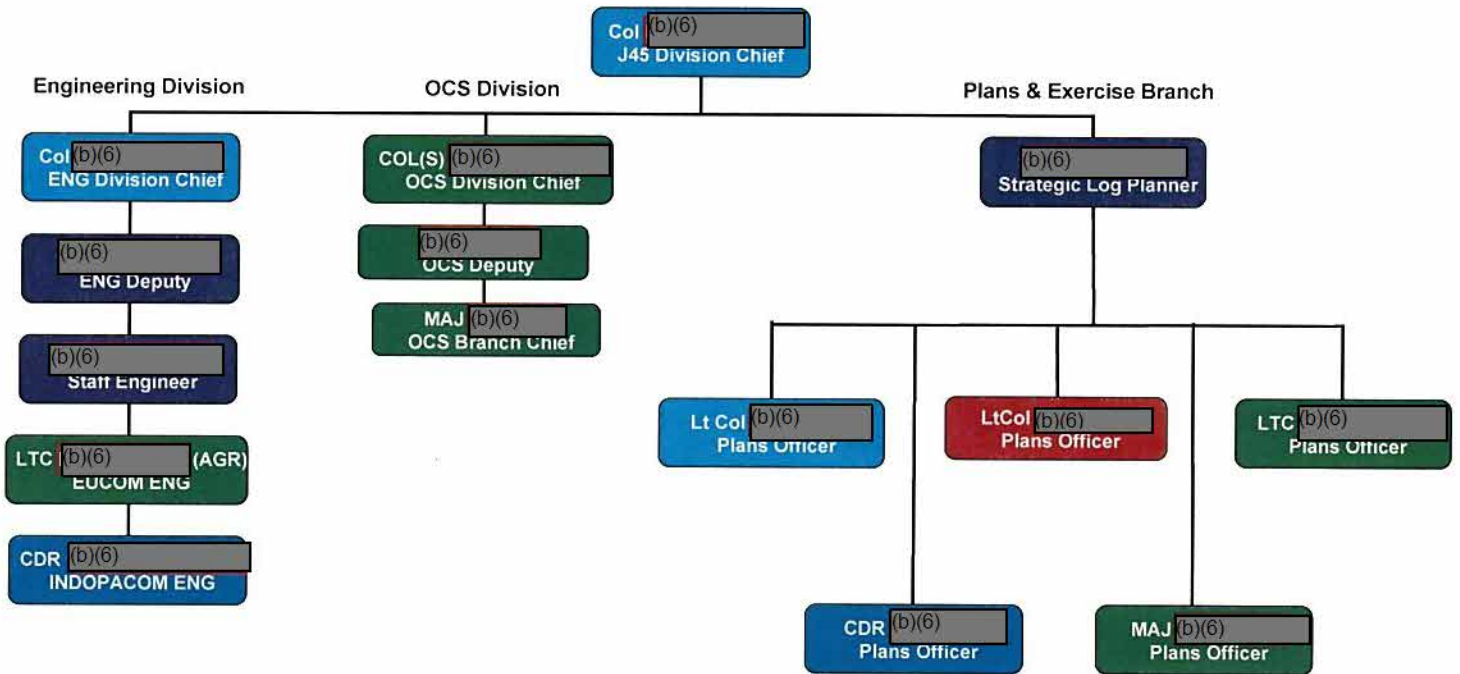

Legend				
 	 	 	 	
USN	USA	USAF	USMC	DoD Civilian

UNCLASSIFIED

J46

Knowledge & Information Division

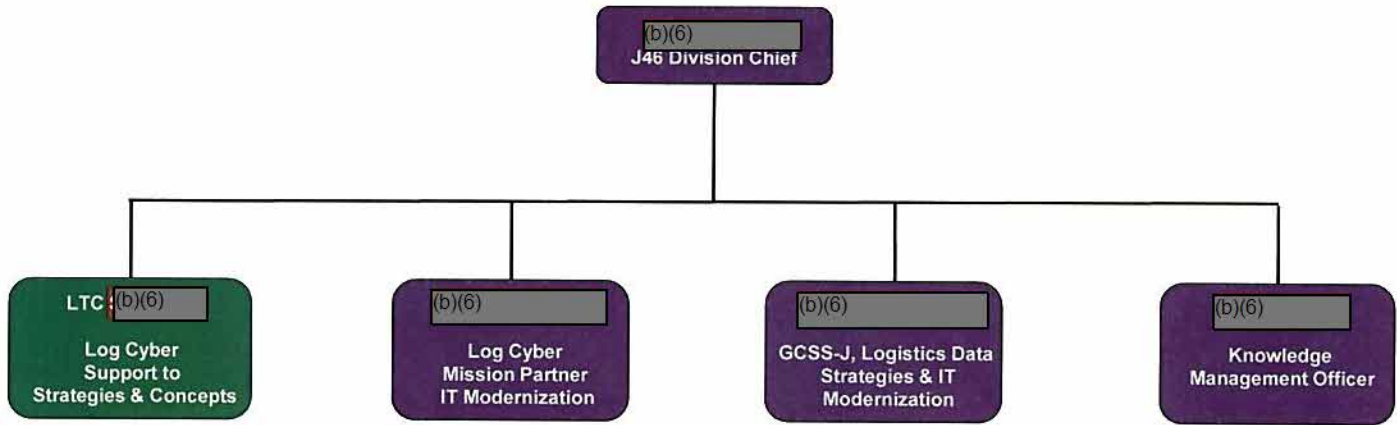

Legend									
	USN		USA		USAF		USMC		DoD Civilian

J48

Strategy, Concepts & Assessments Division

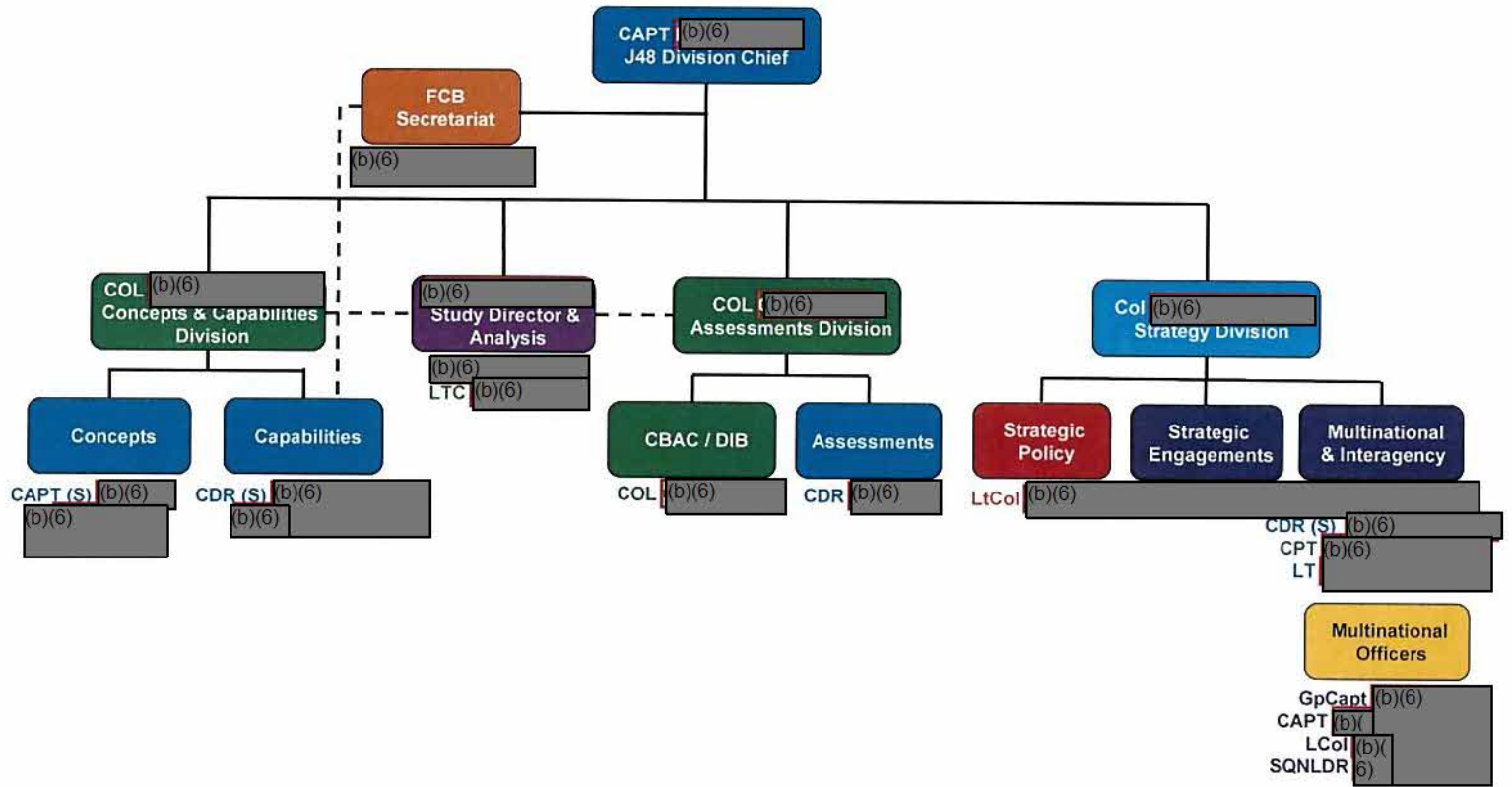

Legend					
USN	USA	USAF	USMC	DoD Civilian	Contract Civilian

DIRECTORATE FOR STRATEGY, PLANS, AND POLICY, JOINT STAFF [J-5]



AFRICA

DEPUTY ASSISTANT CHIEF OF STAFF - AFRICA
 (b)(6)
 (b)(6)
 (b)(6)

ASIA

DEPUTY ASSISTANT CHIEF OF STAFF - ASIA
 (b)(6)
 (b)(6)
 (b)(6)

PROFESSOR

DEPUTY ASSISTANT CHIEF OF STAFF - PROFESSOR
 (b)(6)
 (b)(6)
 (b)(6)

MILSEC

DEPUTY ASSISTANT CHIEF OF STAFF - MILSEC
 (b)(6)
 (b)(6)
 (b)(6)

ENR

DEPUTY ASSISTANT CHIEF OF STAFF - ENR
 (b)(6)
 (b)(6)
 (b)(6)

NSA

DEPUTY ASSISTANT CHIEF OF STAFF - NSA
 (b)(6)
 (b)(6)
 (b)(6)

NSA/CSS

DEPUTY ASSISTANT CHIEF OF STAFF - NSA/CSS
 (b)(6)
 (b)(6)
 (b)(6)

NSA/CSS

DEPUTY ASSISTANT CHIEF OF STAFF - NSA/CSS
 (b)(6)
 (b)(6)
 (b)(6)

NSA/CSS

DEPUTY ASSISTANT CHIEF OF STAFF - NSA/CSS
 (b)(6)
 (b)(6)
 (b)(6)

NSA/CSS

DEPUTY ASSISTANT CHIEF OF STAFF - NSA/CSS
 (b)(6)
 (b)(6)
 (b)(6)

NSA/CSS

DEPUTY ASSISTANT CHIEF OF STAFF - NSA/CSS
 (b)(6)
 (b)(6)
 (b)(6)

NSA/CSS

DEPUTY ASSISTANT CHIEF OF STAFF - NSA/CSS
 (b)(6)
 (b)(6)

Military Security Fares (b)(6)
 IS FT Help Desk (b)(6)
 Building Op (b)(6)
 EFTS Help Desk (b)(6)
 FED Box FCC (b)(6)

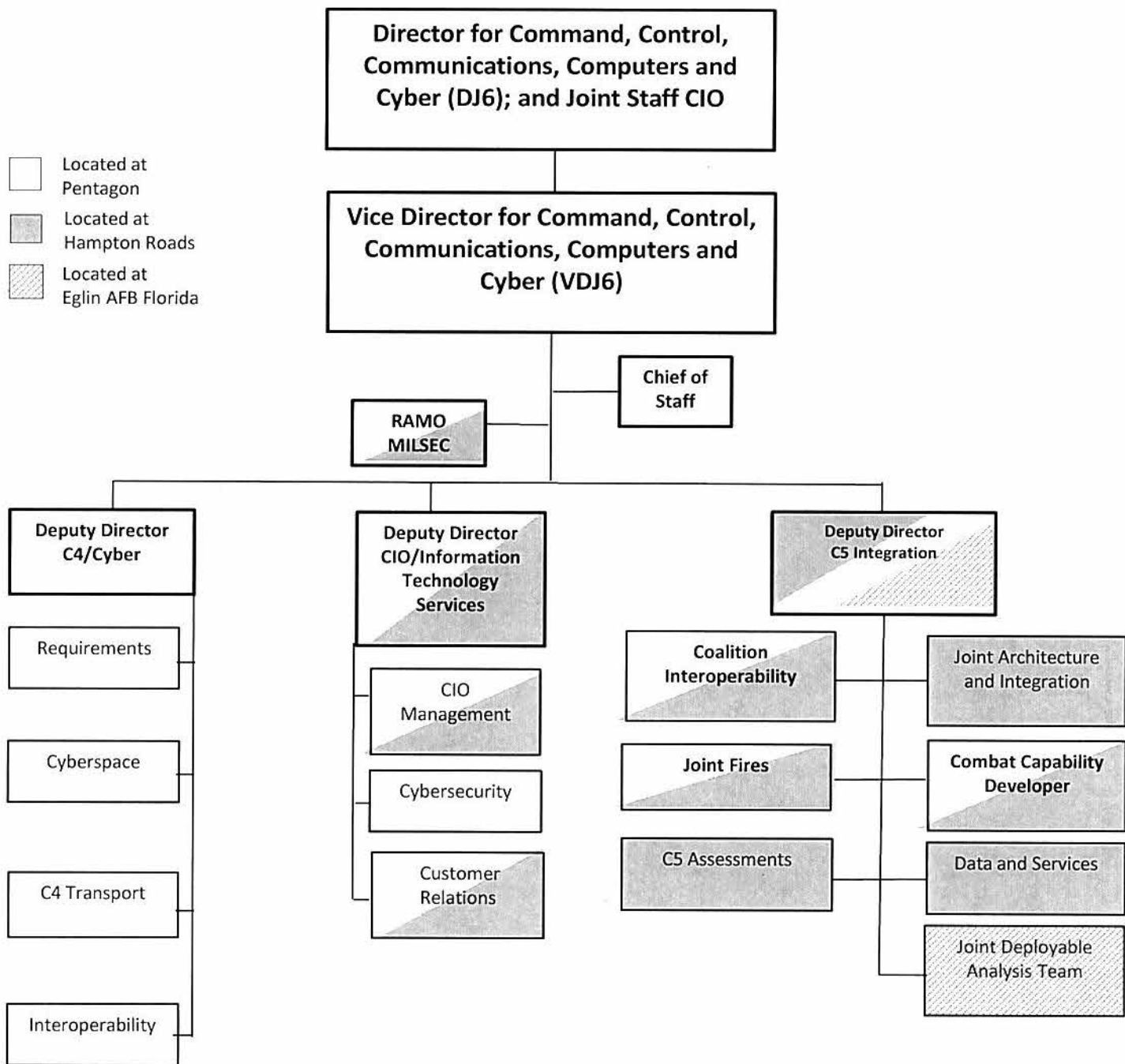

Total Force Organizational Structure – Joint Staff J7

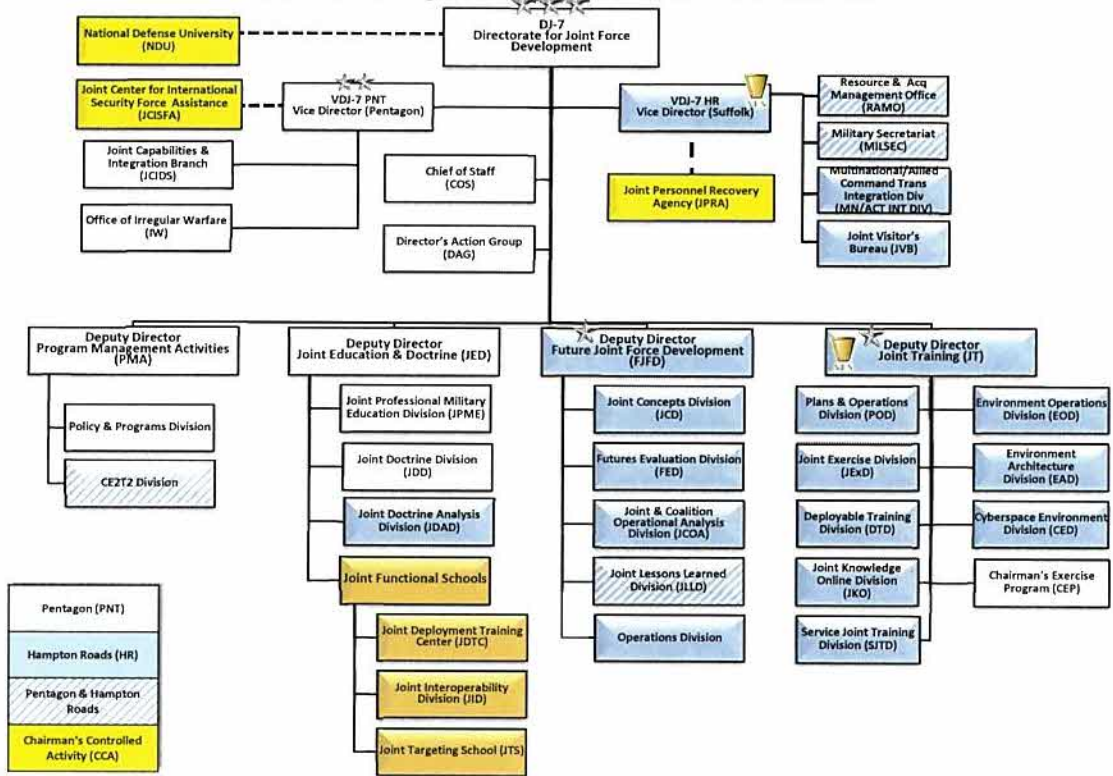

Office of the Director for Joint Force Development, J7
DEPT: B0025A0000 ORC: 5700 TB30: IA0000

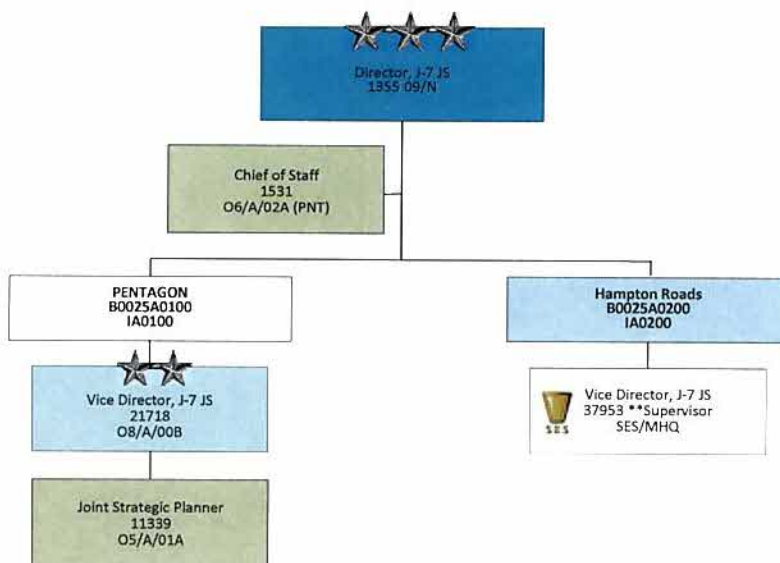

August 1, 2019

International Force Development Division (IFDD)
Dept: B0025A0210 ORC: 5120 TB30: IA0210 (Suffolk)

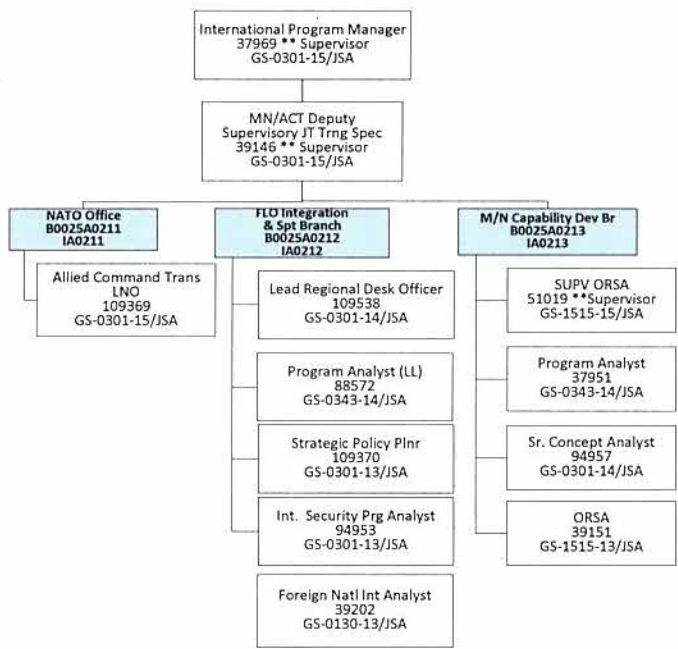

Director's Action Group (DAG)
Dept: B0025A1000 ORC: 4700 TB30: IA1000 (Pentagon)

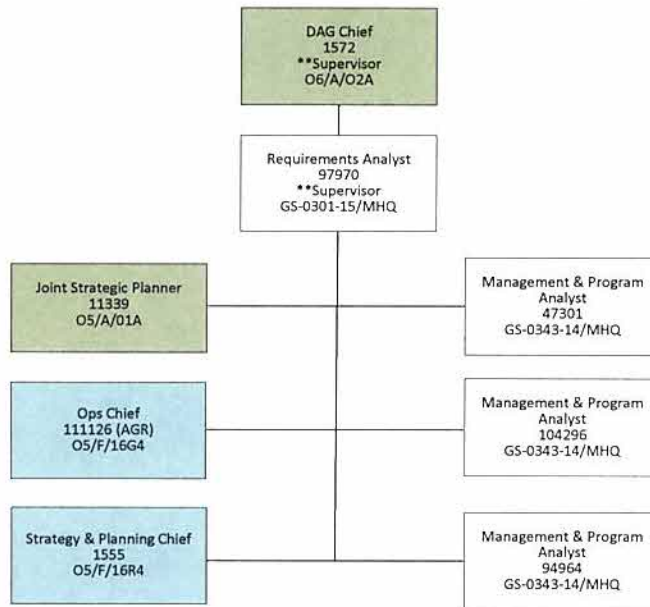

August 1, 2019

Office of Irregular Warfare (OIW)
Dept: B0025A5000 ORC: 4700 TB30: IA5000 (Pentagon)

OIW Chief
39164
IW Assessment Analyst
GS-0301-15/MHQ

Joint Strategic Plnr
11319
O4/A/01A

Management & Program
Analyst
94949
GS-0343-14/MHQ

Joint Strategic Plnr
1573 (NG)
O5/A/02A

Management & Program
Analyst
94961
GS-0343-14/MHQ

Resource & Acquisition Management Office (RAMO)
 Dept: B0025A2000 ORC: 4700 (PNT) 5700 (Suffolk) TB30: IA2000

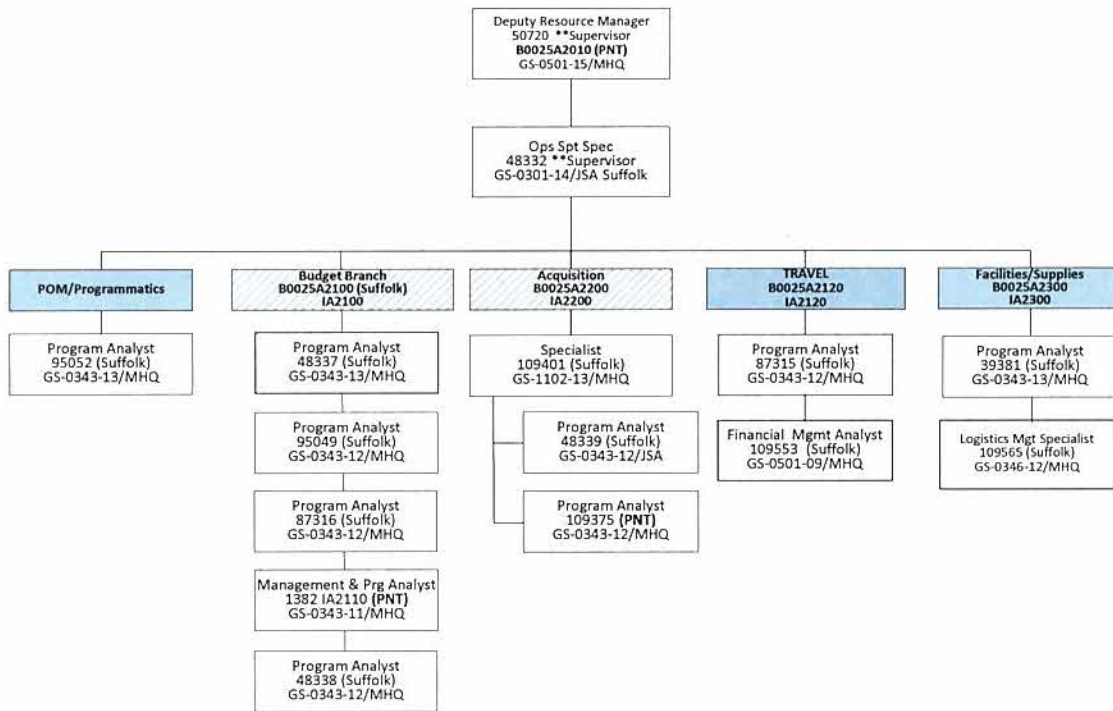

August 1,
2019

MILSEC

Dept: B0025A3000 ORC: 4700 (PNT) 5700 (Suffolk) TB30: IA3000

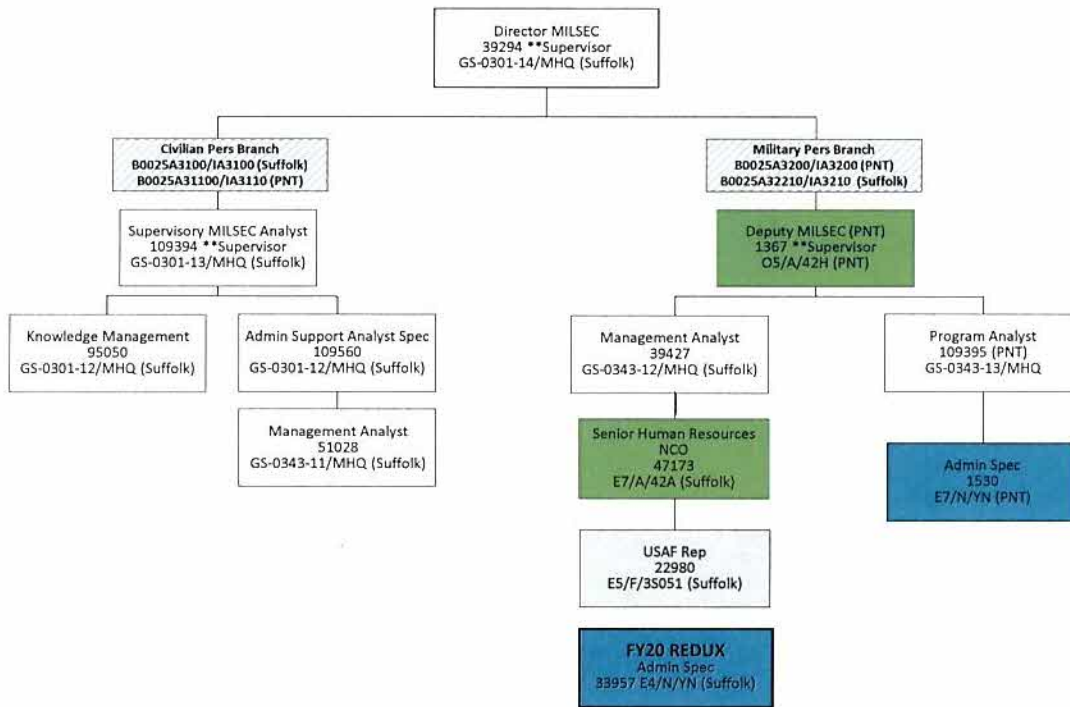

Deputy Director, Program Management Activities (PMA)
Dept: B0025B0000 ORC: 5120 TB30: IB0000 (PNT & Suffolk)

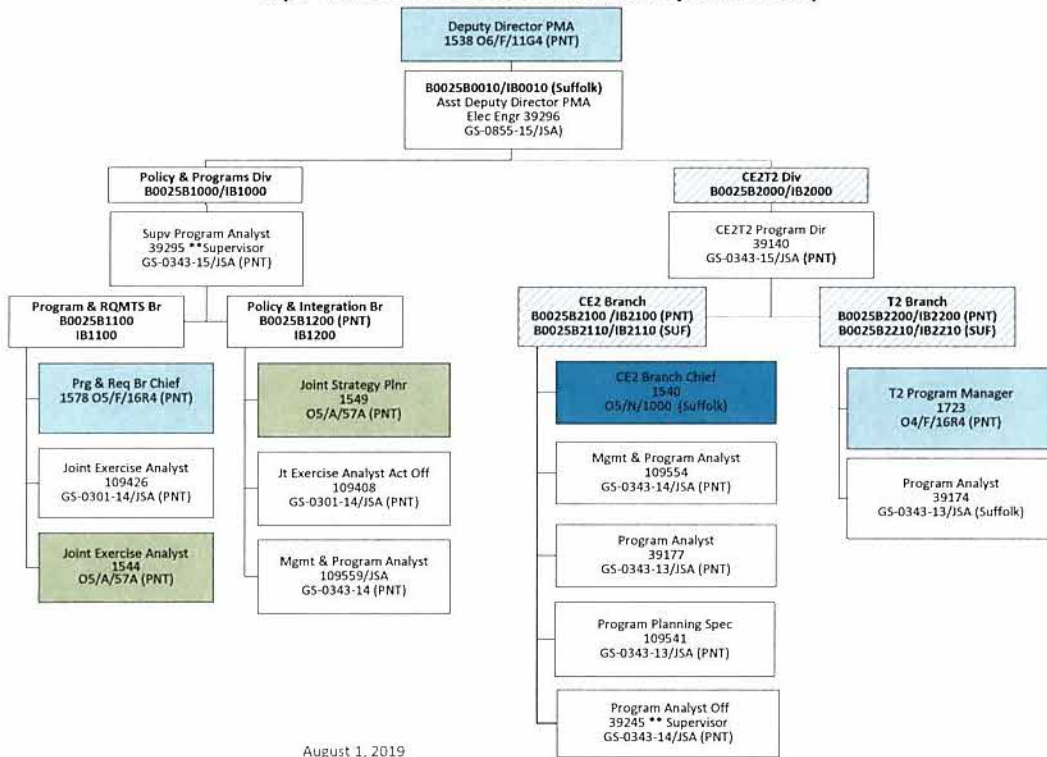

August 1, 2019

Joint Visitors Bureau (JVB)
Dept: B0025A0220 ORC: 5700 TB30: IA0220 (Suffolk)

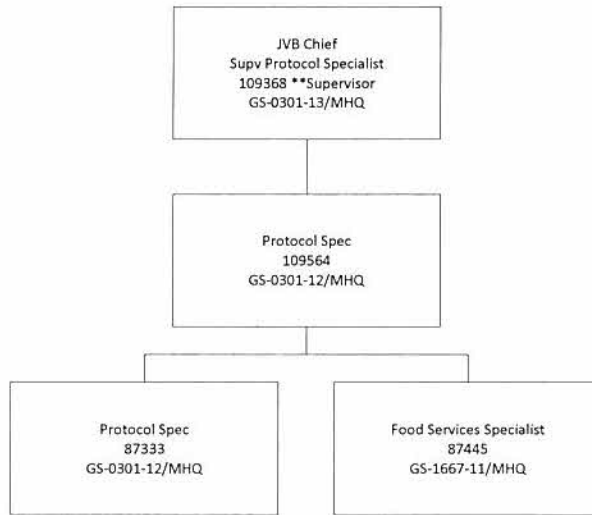

Deputy Director, Joint Education & Doctrine (JED)
Dept: B0025C0000 (PNT) ORC: 5700 (HR) 4700 (PNT) TB30: IC0000/IC0010

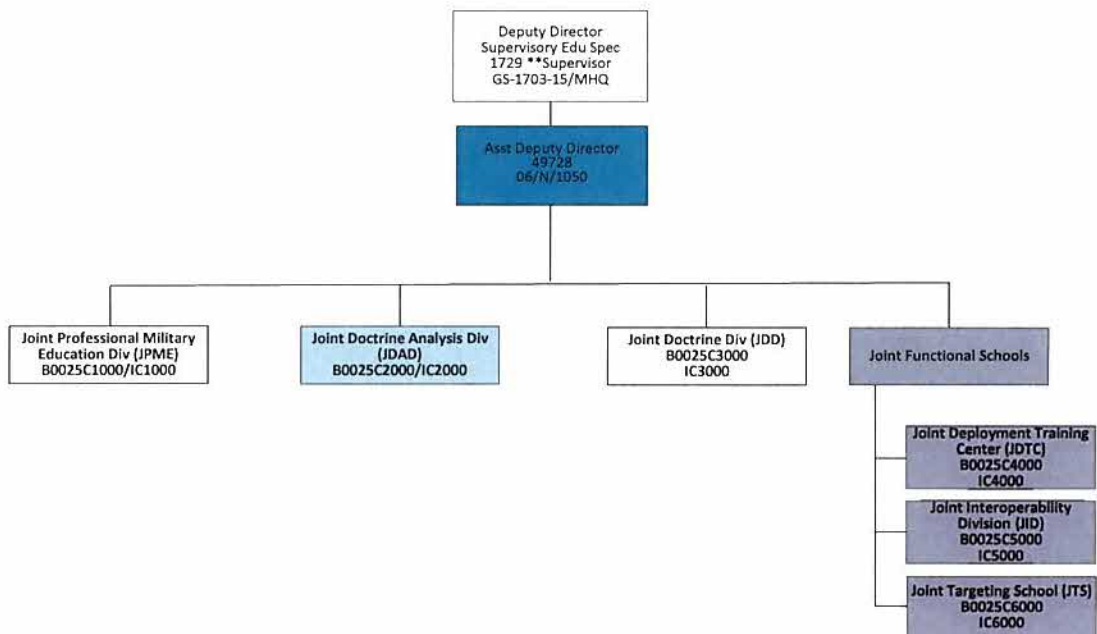

JED
Joint Professional Military Education Division (JPME)
Dept: B0025C1000 ORC: 4700 TB30: IC1000 (Pentagon)

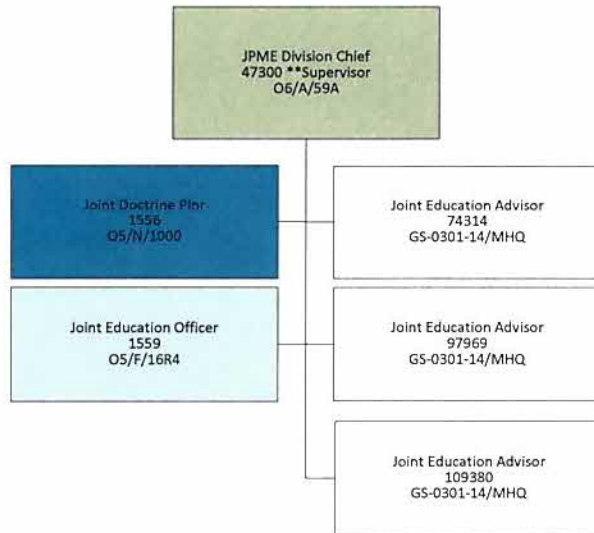

August 1, 2019

JED
Joint Doctrine Division (JDD)
Dept: B0025C3000 ORC: 4700 TB30: IC3000 (Pentagon)

Joint Doctrine Plnr 1592 O5/N/1050	Joint Doctrine Specialist 104689 GS-0301-14/MHQ
Doctrine Strategic Plnr 1560 O5/A/59A (AGR)	Management Analyst 109371 GS-0301-14/MHQ
Doctrine Strategic Plnr 1554 O5/F/11F4Y	Joint Doctrine Specialist 109552 GS-0301-14/MHQ
Executive Assistant 1605 O5/A/59A	Joint Doctrine Specialist 109413 GS-0301-13/MHQ
	Joint Doctrine Strategist 1558 GS-0301-14/MHQ

JED
Joint Doctrine Analysis Division (JDAD)
 Dept: B0025C2000 ORC: 5700 TB30: IC2000 (Suffolk)

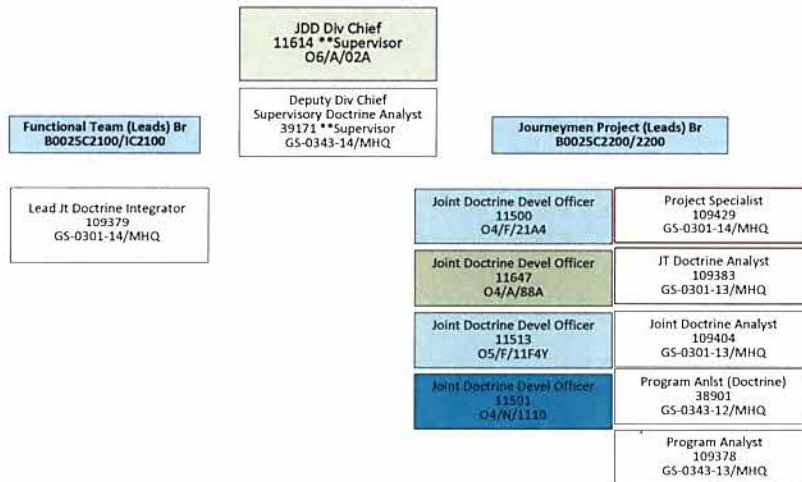

JED
Joint Targeting School (JTS) Dam Neck, VA
 Dept: B0025C6000 ORC: 5120 TB30: IC6000

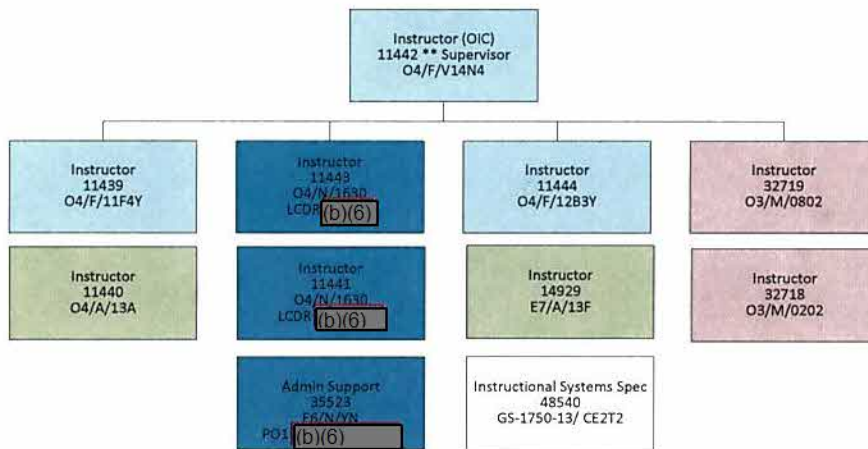

Deputy Director, Future Joint Force Development (FJFD)
Dept: B0025D0000 ORC: 5700 (Suffolk) TB30: ID0000

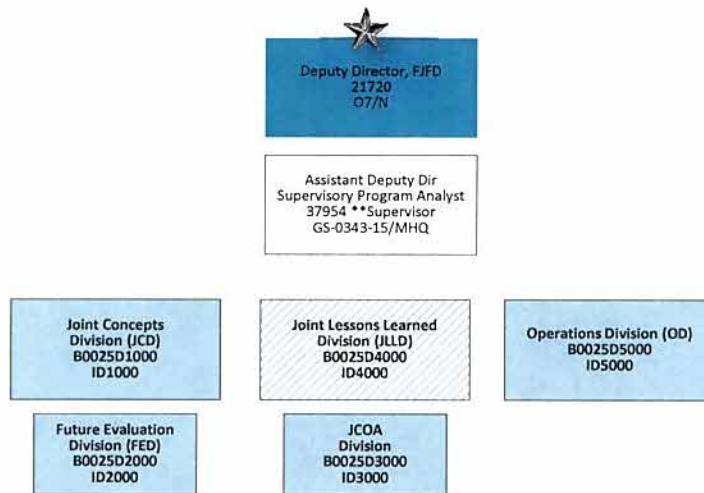

FJFD
Joint Concepts Division (JCD)
Dept: B0025D1000 ORC: 5700 TB30: ID1000

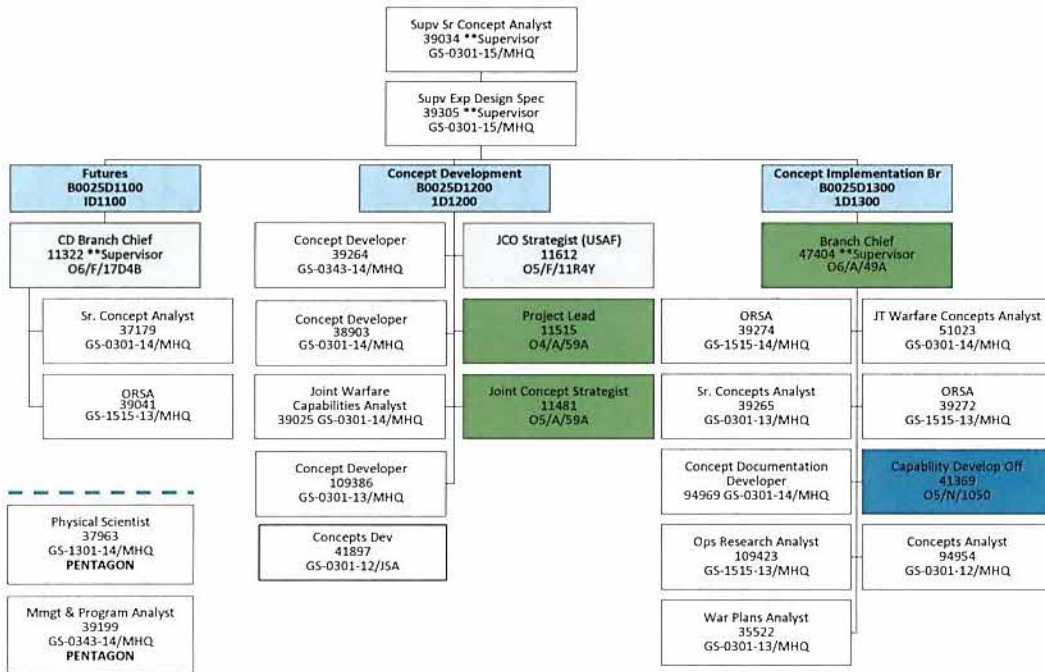

August 1, 2019

FJFD
Futures Evaluation Division (FED)
 Dept: B0025D2000 ORC: 5700 TB30: ID2000 (Suffolk)

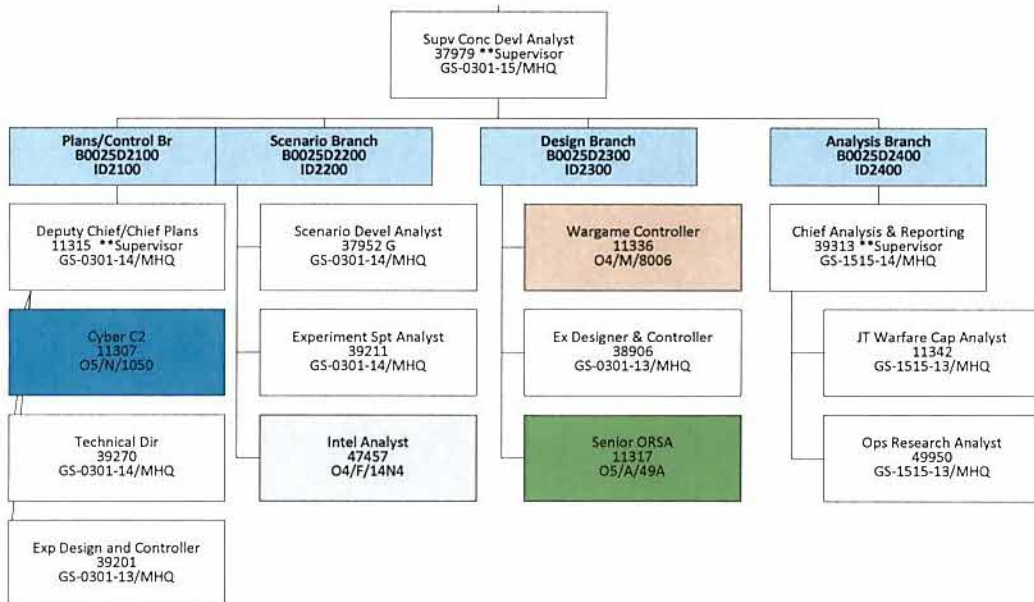

FJFD
Joint and Coalition Operational Analysis Division (JCOA)
 Dept: B0025D3000 ORC: 5700 (Suffolk) TB30: ID3000

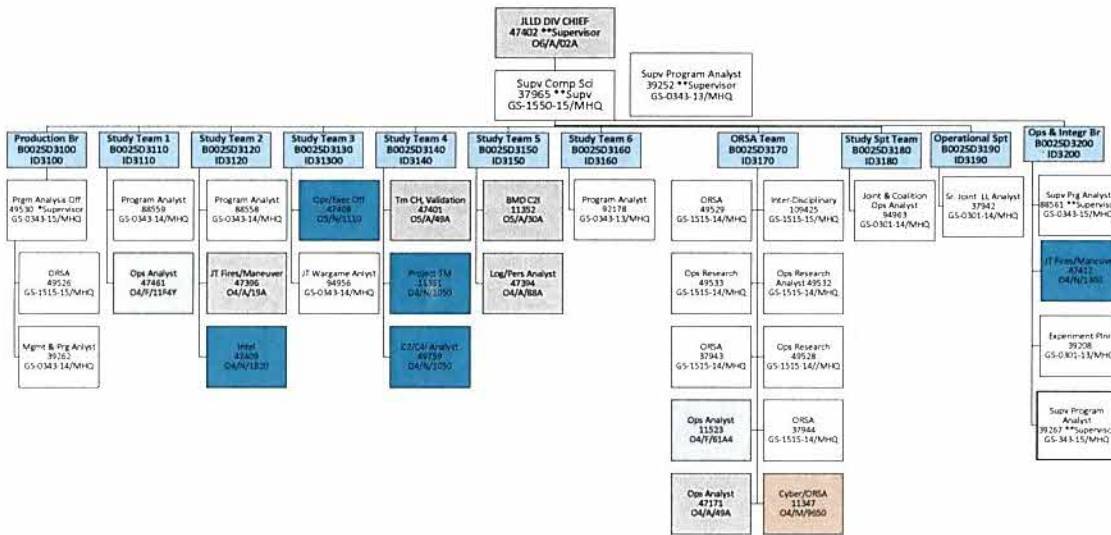

August 1, 2019

FJFD
Joint Lessons Learned Division (JLLD)
 Dept: B0025D4000 ORC: 5700 (HR) 4700 (PNT) TB30: ID4000

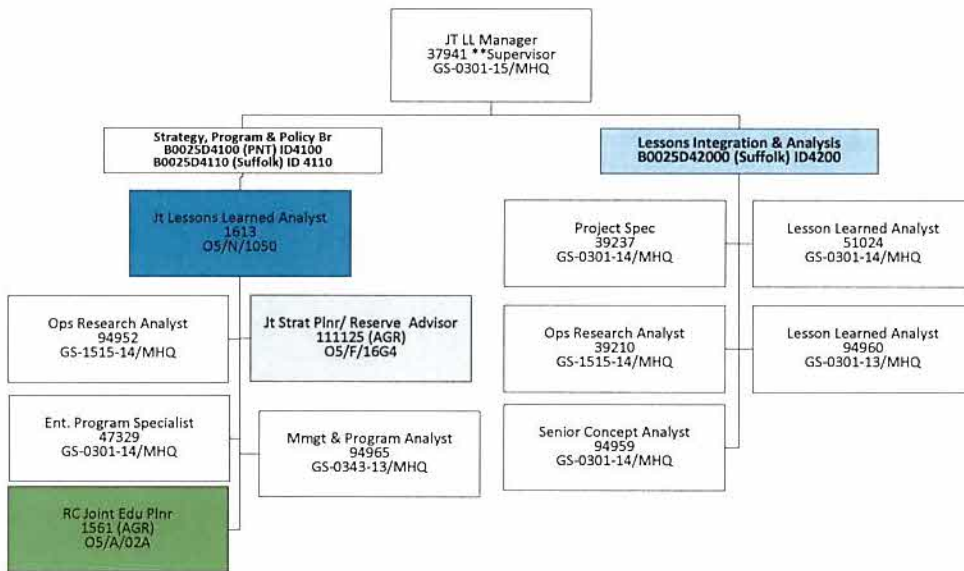

FJFD
Operations Division (OD) Suffolk, VA
Dept: B0025D5000 ORC: 5700 TB30: ID5000

IA Program Coordinator
39209
GS-0301-15/MHQ

Strategy & Ops Plnr
39204
GS-0301-14/MHQ

Program Analyst
39206
GS-0343-13/MHQ

Frgn Ntnl SME Integ Analyst
39311
GS-0301-13/MHQ

Ops Research Analyst
109422
GS-1515-13/MHQ

August 1, 2019

JT
Plans and Operations Division (POD)
 Dept: B0025E1000 ORC: 5120 TB30: IE1000

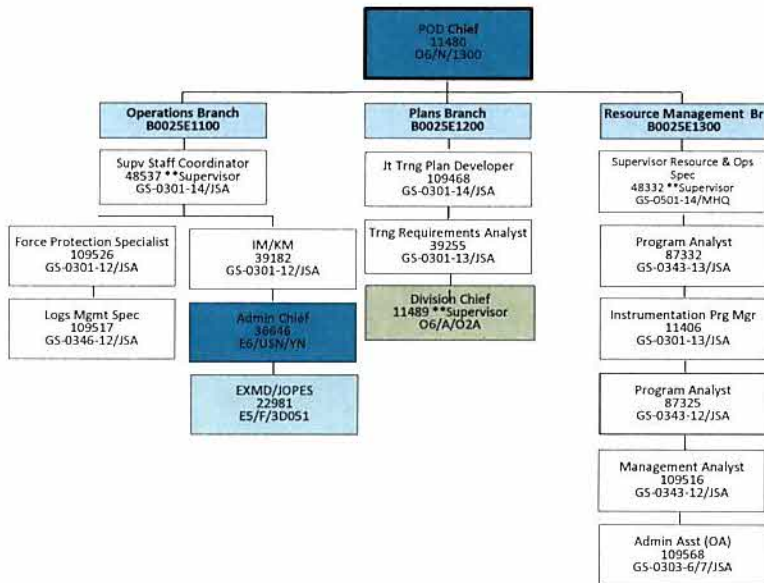

August 1, 2019

JT - Deployable Training Division (DTD) Dept: B0025E3000 ORC: 5120 TB30: IE3000

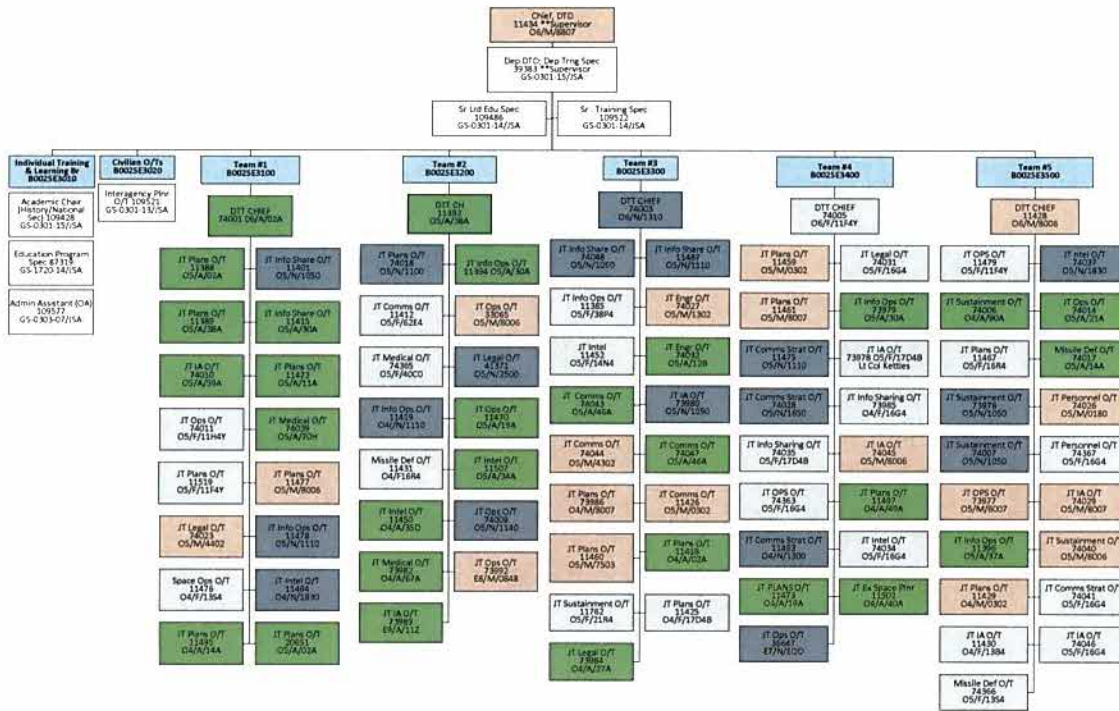

August 1, 2019

JT – Environment Operations Division (EOD) – Dept: B0025E6000 TB30: IE6000 ORC: 5120

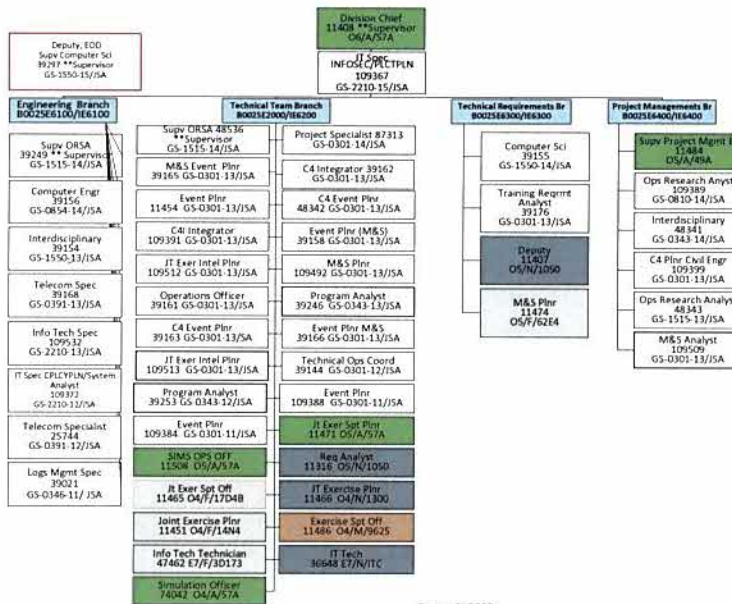

August 1, 2019

JT – Environment Architecture Division (EAD) – Dept: B0025E7000 TB30: IE7000 ORC: 5120

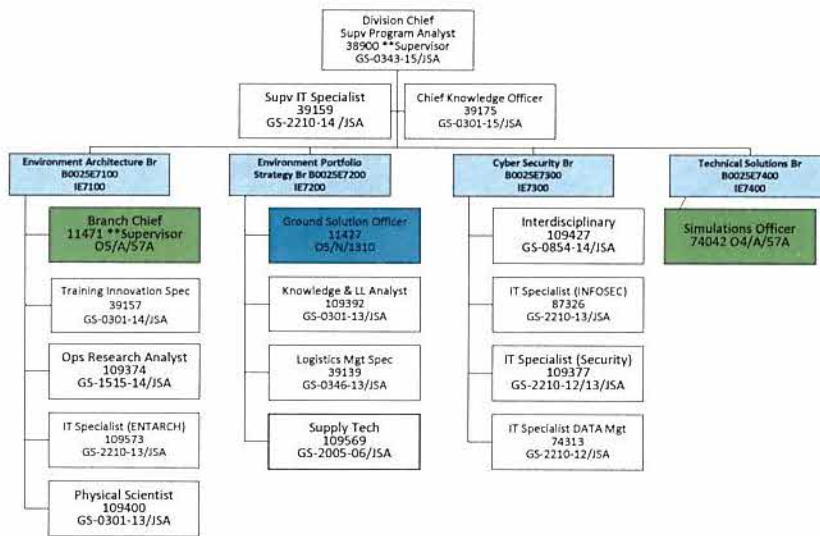

August 1, 2019

JT
Cyberspace Environment Division (CED)
 Dept: B0025E9000 TB30: IE9000 ORC: 5120 (JSA) 5700 (MHQ)

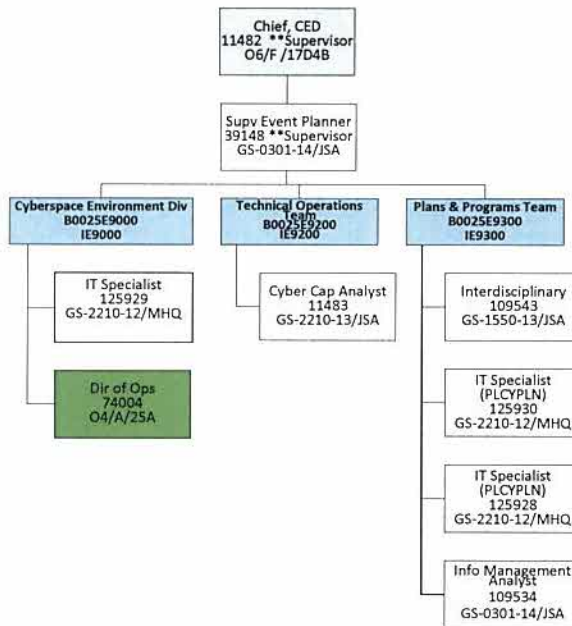

August 1, 2019



J8 Organization Structure

